

Session Fourteen:

Best EMC Installation Practice for Variable Speed Drives – Understanding the Main Differences and Goals Between Earthing and Bonding

Eduardo Gie

Technical Manager, Danfoss Pacific – Power Electronics

Abstract

The application of variable speed drives (VSDs) or/ variable frequency drives (VFDs) are well-known for their benefits. They are energy efficient and flexible in the controlling of processes and machinery using standard AC or PM motors. Although many VSD's can provide efficient control, depending on the design and installation of the VSD, they may result in increased problems elsewhere in the electrical system.

When electrical noise problems arise, it can result in unreliable operation of other equipment, increased liability, increased project timescales and result in non-compliance with regulatory requirements. It can cause loss of revenue, since it can be a very time-consuming and a costly exercise to resolve them.

Taking a "prevention is better than cure" approach during the front end design, selection and installation of VSDs, can ensure that these problems are avoided.

This presentation highlights the recommended EMC best practice to avoid undesired Electromagnetic interference when installing VSDs in commercial and industrial applications to:

- 1/ assure personnel's safety and the protection of installations against power system faults and lightning (Earthing),
- 2/ allow a low impedance path to divert the power faults current and high frequency currents without passing through other equipment and to ensure equipotential (Bonding),
- 3/ enhance the equipment's performance,
- 4/ maximize commissioning timescales,
- 5/ ensure reliable operation,
- 6/ to comply with EMC regulations.

Introduction

The application of variable speed drives (VSD) today, (also known as VVVF, VFD or AFD) in all automated process plants is a standard equipment that controls the speed of Asynchronous Motors (AC Motor) or Permanent Magnet Motors (PM Motor). Besides its ability to adjust the motor speed infinitely to the production process requirements, it also offers numerous advantages such as: energy saving, reduction of mechanical stress on machinery, improvement of the displacement power factor ($\cos \phi$) of the motor, etc.

Energy can be saved by simply matching the required speed. In a constant torque (CT) application (i.e. conveyors) the electrical energy is ~50% of the rated power at half the motor speed; while in variable torque applications (i.e centrifugal pumps or fans) the electrical energy is ~12.5% of the rated power at half the motor speed.

However, depending on the design and installation of the VSD, they may result in increased problems elsewhere in the electrical system due to their secondary effects such as harmonic distortion, motor insulation stress (dv/dt), motor acoustic noise and leakage current (RF energy). All VSD manufactures have solutions to overcome these potential problems but one of the most common misunderstandings is to believe that the inclusion of the RFI filters with the VSD is sufficient to ensure that there are no EMC problems.

This paper will only cover the Radio-Frequency energy radiated and conducted in a range from 150 KHz to 30Mz and discuss the reasons why it is important to follow best practice for the installation of VSDs, as to ensure the problems due to leakage current are avoided.

The information provided in this paper does not consider the safety aspects as such, but it is important for me to mention that safety must never be compromised for the sake of EMC.

The nature of interference

VSDs control the speed of AC motors by varying the frequency and voltage of the electrical supply to the motor. The vast majority of VSD today uses Pulse Width Modulation known as PWM for the generation of a 3 phase voltage with corresponding frequency. In layman's terms the PWM produce a varying output frequency and voltage by switching transistors on and off at a fast rate (typically at 3,000 times per second and up to 16,000 times per seconds) and with very short rise times of each pulse (~0.2microsec). Figure 1 shows an inverter section with six transistors (IGBT type) and figure 2 shows a PWM waveform at the output of a VSD.

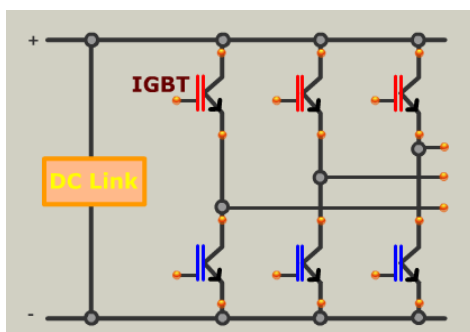

Figure 1 – Inverter section with 6 IGBTs

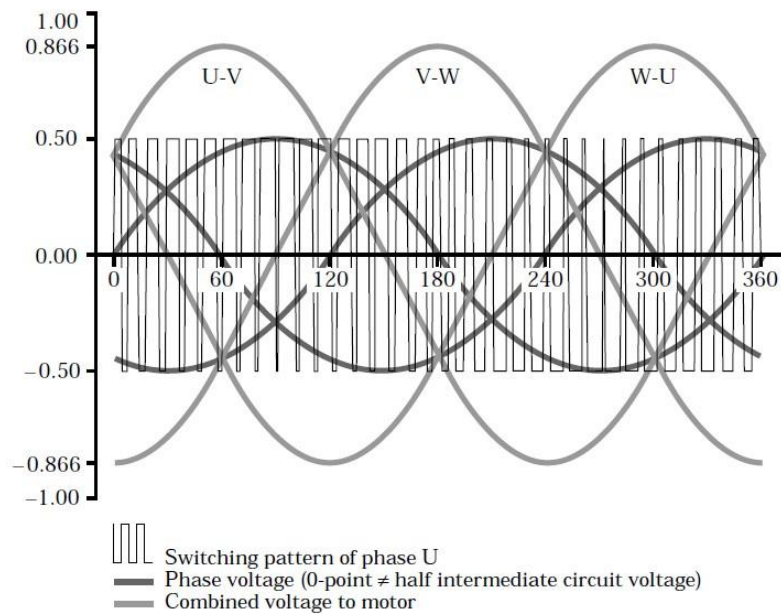

Figure 2 – PWM VSD output voltage waveforms

During the early days of digital electronics (~1970), people used to observe flickering on their television or interference on the radio when switching on a light switch in the house. Just imagine how difficult it would be listen to the radio when a switch (which is in this case is represented by a transistor) turn on and off at 3000 times per second or more.

Such a phenomenon is a result of radio frequency interference (RFI) or electromagnetic interference (EMI). The switching of the light switch results in interference on the mains supply which affects the operation of the television or radio.

The high frequency switching of relatively high currents by a VSD's output transistors and the very short rise times of each pulse can result in high levels of RFI noise radiated and/or conducted onto the mains supply or other control cables causing unintentional and unexpectedly interference in other electrical devices, especially when the level RFI noise is too high than allowable limits.

Hence the control of the Electromagnetic Compatibility (EMC) has been an increasing necessity to ensure reliable operation. It minimizes liability risk, reduce project time scales and help to meet with local standards & code of practice.

Remember that "prevention is better than cure. The best time to consider all aspect of EMC is during the upfront design, selection and installation of VSDs to ensure these problems are avoided.

The need to comply EMC regulations

The level of allowable conducted RFI noise from the installation of a VSD is defined in the Australia Standard AS 61800.3-2005. This standard is specific to VSDs and identical to IEC 61800-3:2004.

In some countries the EMC performance of VSDs (and other electrical/electronic equipment) is governed by legislation (i.e. law). For example, in the European Union, VSDs and other electrical/electronic equipment must be CE marked to be legally sold. The main purpose of the CE and C-Tick marks is to allow free passage of the equipment within European Economic and Pacific areas respectively.

The presence of the CE and C-tick marks provide guarantees that manufacture of the equipment meet the minimum requirements as defined by standards, IEC61800-3:2004 for Europe and AS61800-3:2005 for Australia and New Zealand.

At the time of writing this paper, the Australian Communication and Media Authority have advised the forthcoming changes to the C-Tick labeling arrangements to a new one (RCM mark). Suppliers will have a ~3 years transition period from March 2013 until February 2016. The testing and record-keeping requirements will not change.

In New Zealand an EMC Compliance Code of Practice (COP) for the supply, installation and operation of Power Drive System (PDS) was put together by the Ministry of Economic development. This was in response to industry stray current electrical safety concern. The COP is based on the AS 61800.3.2005 which includes not only best installation practices but also the installation test practices built from local research and experience.

It is important to highlight that the AS 61800.3-2005 (IEC61800-3:2004) standard specify the EMC requirements and the recommended engineering practice for power drive system, NOT just only for VSDs. The Power Drive System consists of a Complete Drive Module (VSD), the motor and its interconnection such as motor cables, control cables, supply cables, junction box, contactors, etc. except for the driven load. Figure 3 shows all components comprise in PDS.

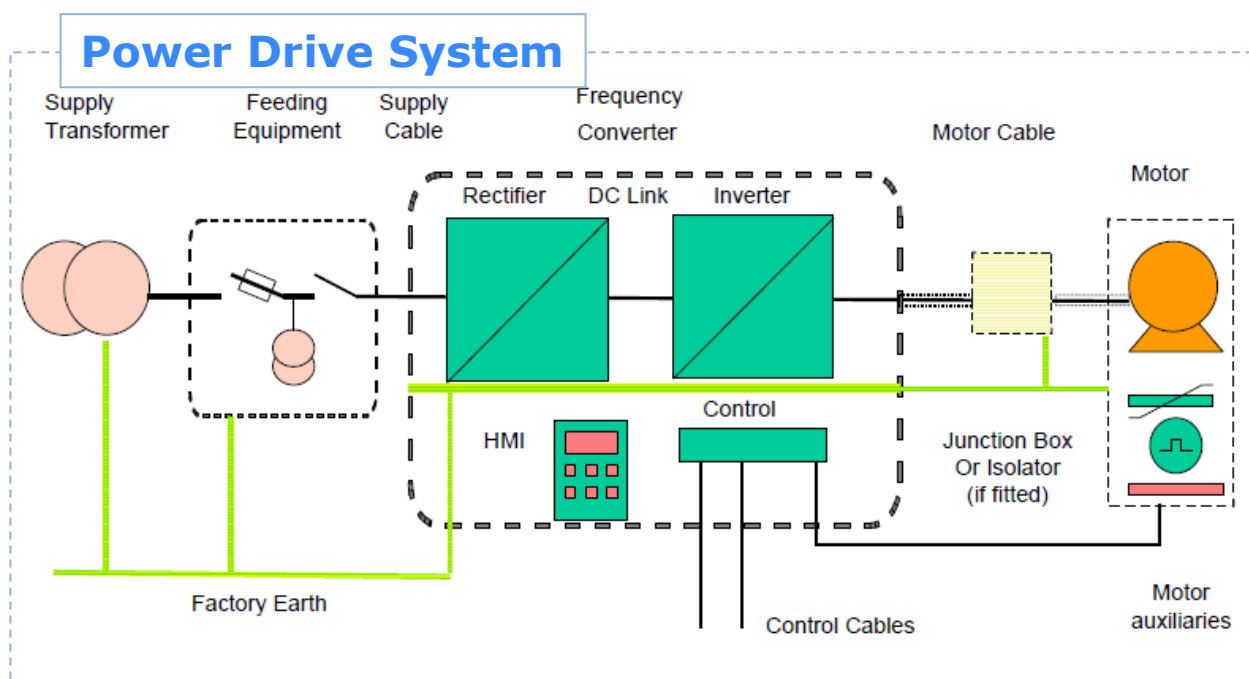

Figure 3 - Power Drive System as per AS61800.3.2005

Both IEC & AS standards defined:

- a. two environment types (1st & 2nd Environment) depending on where the point of common coupling (PCC) is located.
- b. four different product categories (C1, C2, C3 and C4) which defines different limits for conducted RFI noise into the mains terminal (in the frequency range of 150Khz to 30MHz) depending on rated voltage & current as well as if it is intended to be installed by a EMC professional or not.

A full definition of the different environments, product categories and performance requirements can be found in the standard, but below is a summary.

1st Environment includes domestic premises and buildings/facilities which are directly connected to a low voltage (e.g. 230/400V) mains supply which also supplies buildings used for domestic purposes. Directly connected means that there is no intermediate transformer between these buildings. For example, a commercial building in the CBD of a city which shares the 230/400V secondary supply from a transformer with an apartment block close by would be a 1st Environment installation.

2nd Environment includes all buildings/facilities which are not directly connected to a low voltage mains supply which also supplies buildings for domestic purposes. For example a facility with a dedicated low voltage mains supply transformer would be a 2nd Environment installation.

Category C1 – this category applies to VSDs connected to a mains supply <1000 volts for use in the 1st Environment.

Category C2 – this category applies to VSDs connected to a mains supply <1000 volts that when used in the 1st Environment will be installed and commissioned only by a professional. It defines a professional as a person or organization having the necessary skills in installing VSDs including their EMC aspects.

As can be seen from Figure 4, category C2 VSDs can emit a higher level of conducted RFI noise than category C1. The standard assumes that if the VSD will be installed by a professional, they will follow the correct EMC installation procedures, possibly including the installation of a separate RFI filter if necessary, and therefore the conducted RFI performance of the VSD itself does not have to be as good as required by category C1. Please note that the y-axis of Figure 4 has a dB scale. With this scale, a difference of 10dB between category C2 and C1 limits equates to the actual micro-volt limit for category C2 being 3.3 times the limit for category C1.

Category C3 – this category applies to VSDs connected to a mains supply <1000 volts for use in the 2nd Environment.

As can be seen from Figure 4, category C3 VSDs can emit a higher level of conducted RFI noise into the mains supply than category C1 and C2 VSDs with different limits defined for ≤ 100 amps and > 100 amps. The standard assumes that if a facility has a dedicated low voltage mains supply transformer, any RFI noise from the VSDs will remain within the facility's installation and not propagate to other electricity consumers. Therefore if any problems occur within the facility it is the responsibility of the end user to resolve to their own satisfaction.

The standard also states that if a VSD cannot meet category C1 or C2 limits, the VSD manufacturer’s instructions must include a warning stating that the VSD is not intended to be used on a low voltage public supply networks which supply domestic premises; and that radio frequency interference is to be expected if used on such a network.

Please note: Many hospitals, airports, pharmaceutical and semiconductor electronic cleanroom facilities have their own dedicated low voltage mains supply transformers and therefore by definition can be classed as 2nd Environment installations. However, these facilities incorporate many other sensitive items of equipment. So, AS61800.3 suggests additional “mitigation measures may have to be employed” for such sensitive installations. In other words follow the requirements as per Category C1/C2 for such installations.

Category C4 – this category applies to VSDs connected to a mains supply ≥ 1000 volts or rated ≥ 400 amps or for the use in complex systems in the 2nd Environment (such as networks isolated from earth or connected through a high impedance IT system). Figure 4 does not show the C4 emission limits because C4 limits are defined “outside” the boundary of the installation and not only for the PDS like categories C1, C2 and C3. It means that limits will apply between the premises; the user of the PDS and its neighbor. If the neighbor belongs to the 1st environment table 19’s limits apply (same level as C1) while if they belong to the 2nd environment table 20’s limits apply (same level as C2).

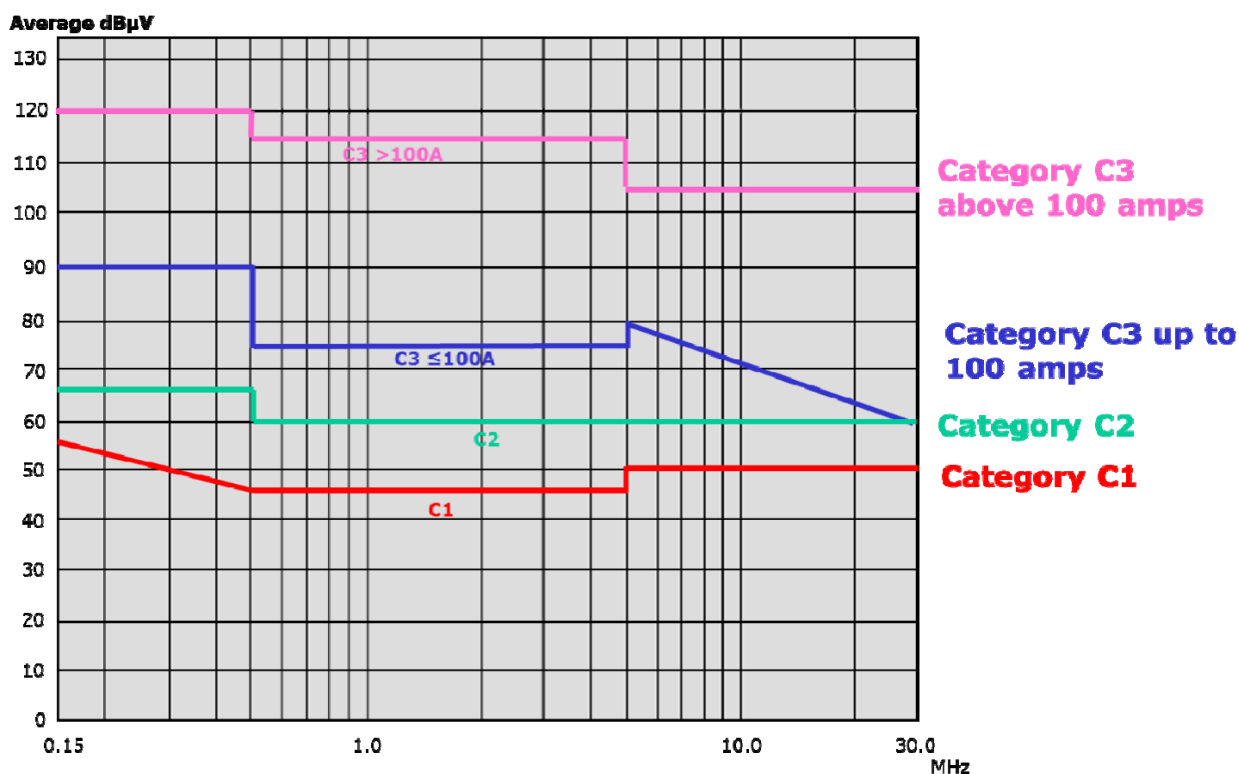

Figure 4 - Limits for mains terminal disturbance voltage in the frequency band 150 kHz to 30 MHz as per AS61800.3.2005.

Classification by category	C1	C2	C3	C4
Environment	1st Environment	1st or 2nd Environment (operator decision)	2nd Environment	2nd Environment
Voltage/current	< 1000 V			> 1000 V In > 400 A Connection to IT network
EMC expertise	No requirement	Installation and commissioning by an EMC expert		EMC plan required
Limits according to EN 55011	Class B	Class A1 (plus warning notice)	Class A2 (plus warning notice)	Values exceed Class A2

Table 1 Classification of categories C1 to C4 as per AS 61000.3.2005

Fundamentals of Electric, Magnetic and Static fields

To be able to understand the reason why VSD’s manufacturers recommend strict electrical installation techniques for their equipment, it’s imperative to explain the basics of the Electric, Magnetic and Static fields as well as how they propagate and couple into other cables.

The word Electromagnetic consists of two root words electric and magnetic. We are therefore dealing with two types of fields simultaneously.

According to the Electromagnetic Theory (Maxwell’s equation) a time variant current (AC) within a transmission line (a cable) develops a time-variant **magnetic field**. If there is an adjacent conductor, a portion of this magnetic field will link to that conductor.

The magnetic field can be represented by a mutual inductance (or loop antenna) and is measured in Amps/meters [A/m].

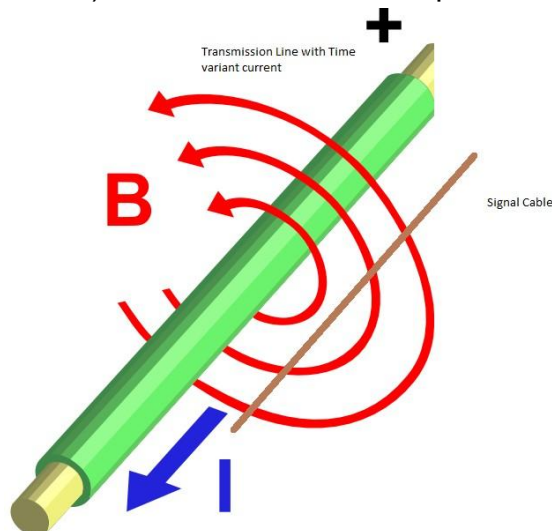

Figure 5 – Flux lines associated with current in transmission cable

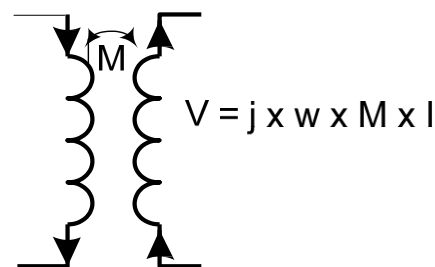

Figure 6 – Mutual Inductance

The magnitude of the voltage depends on the rate of change current, so a high change rate of current implies a high inductive voltage

$$V = L \times (di/dt) \text{ - (eq 1)}$$

On the other hand, a time varying voltage between two conductive metallic components separate in the space with opposite polarity develops an **Electric Field**.

The electric field can be represented by a capacitor (or dipole antenna) and the field is measure in Volts/meters [V/m].

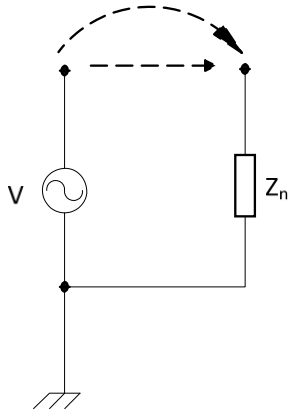

Figure 7 – Electric field

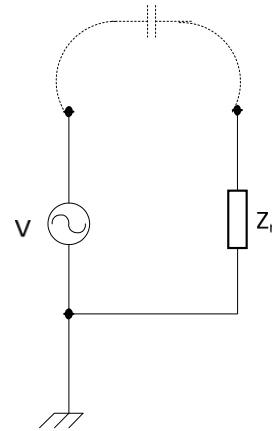

Figure 8 – Equivalent circuit

The capacitance increases with the area of the conductors and decreases with separation distance between the conductors. When the voltage between the conductor changes, there will be a change in the charge on the conductors which implies a current flow through the conductors.

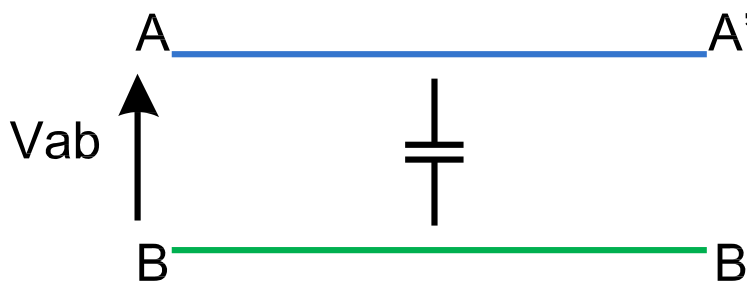

Figure 9 – Capacitance between two conductors

The magnitude of the current flows depends on the rate of change voltage, so a high rate of change of voltage implies a high capacitive current.

$$I = C \times (dv/dt) \text{ - (eq2)}$$

or can be also expressed as $I = j \times 2 \times \pi \times f \times C \times V \text{ (eq3)}$

Static field is commonly classified as Electrostatic Discharge (EDS), transient surge or lightning. The main characteristic of a static event is that it starts with a very slow buildup of energy, (typically seconds or minutes) which is then stored in the capacitance of the structure such as i.e. human body followed by a very

rapid breakdown, typically in nanoseconds. With this pulse in the nanosecond range, the discharge energy can produce EMI in the frequency range of 300 MHz to as high as 1GHz. Static charge distribution creates an electric field hence can be represented by a capacitor.

Both Electric and Magnetic fields are referred to in this paper as radio frequency (RF) energy. A VSD creates RF energy by switching transistors on and off at a fast rate. This RF energy can be radiated and then coupled onto other equipment's control & supply cables through either capacitive or inductive means. The RF energy can also be conducted to other equipment through a common impedance path such as an earth connection.

Understanding all possible noise coupling mechanisms will assist the electrical installer to reduce the coupling between the source of noise (i.e. VSD's motor cable) and other electronic equipment.

Electromagnetic Field Coupling

1. Electrostatic or Capacitive Coupling – Electric Field dominant

The figure 10 below show a simply VSD installation with unscreened motor cable (which in this case is considered as the source of disturbance), while figure 11 show a zoom in on one of the outputs (i.e. phase w) running close to communication cable (known as the victim).

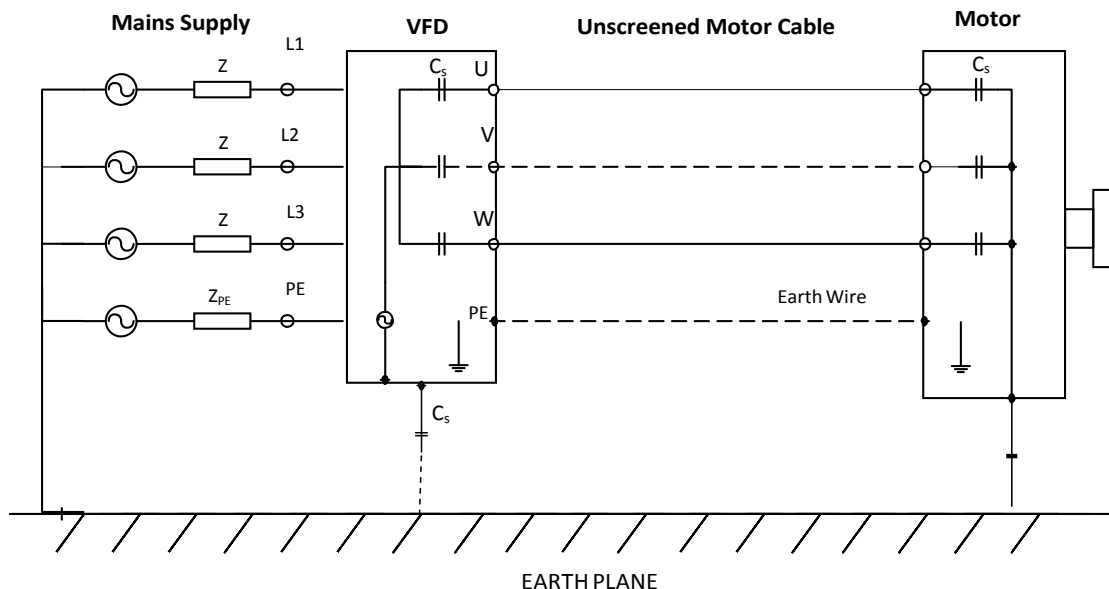

Figure 10 – VSD with unscreened cable

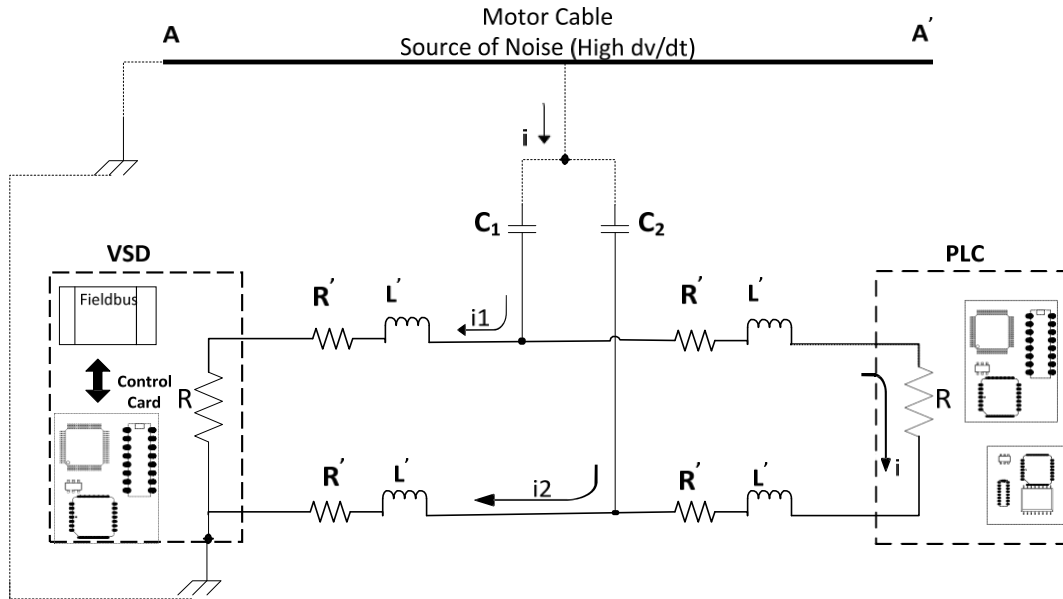

Figure 11 – Mechanism of Electrostatic or Capacitive Coupling

As per equation 2, $I = C \times (dv/dt)$, a voltage change on the motor cables with respect of the communication cable will cause a current flow through the coupling capacitance C_1 and C_2 into the communication cable and back to source via earth. The magnitude of the capacitive coupled current depends on:

- a. The rate of change of the interference voltage, dv/dt i.e. 3 kHz to 16 KHz
- b. Capacitance between the source of disturbance (i.e. motor cable) and the communication cables.

Note that the capacitance value depends on the separation distance between the source of disturbance (motor cable) to the communication cable as well as the distance over which the cables are run in parallel.

The coupling of a high capacitive current into the communication cable results in the development of high voltage through the communication cables inductance (L) and the resistance (R) causing then communication errors and/or possible damage to the communication cards on either PLC or VSD.

To reduce the effects of the capacitive coupling between the source of disturbance (motor cable) and the victim (communication cable) it is necessary to:

- a. Increase separation between source and victim cables.
- b. Run communication/signal cables along different routes to power cables or where they need to cross do it at right angles to each other.
- c. Use twisted pair cable to provide a balance capacitive coupling
- d. Use of screen around the signal cables to ensure that couple currents flow through capacitance C to screen and then to earth instead through the communication/signal conductor, figure 12.

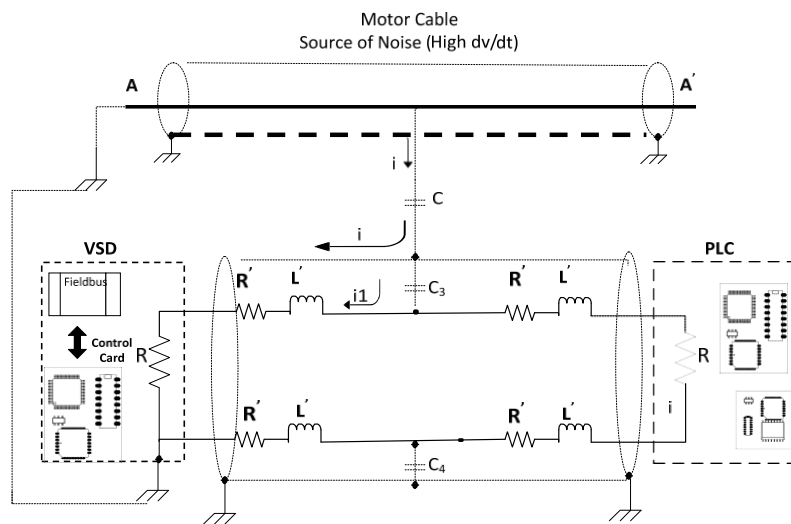

Figure 12 – Screening to avoid capacitive coupling

e. The capacitive couple currents flowing through the screen impedance result in a voltage drop, so it is important to use screen with high conductivity (in other words with low transfer impedance). Transfer impedance indicates the performance of the screen cable and the value solely depends on the construction of the screen. Another important factor in the selection of screen cables is the amount of cable surface covered by the screen, which should be at least 80%.

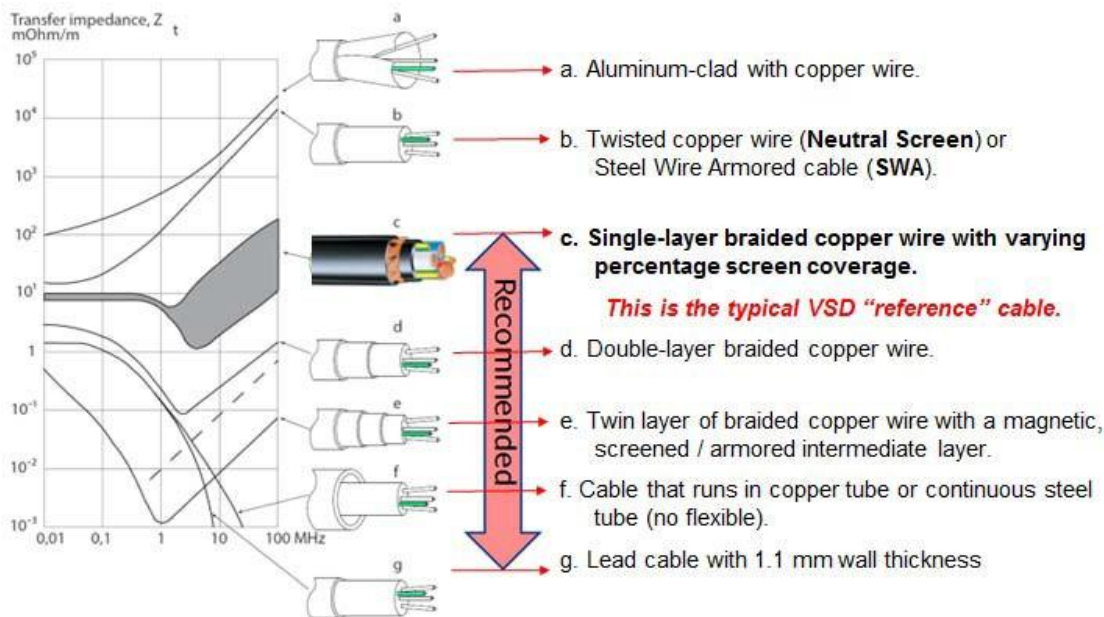

Figure 13 – Type of Screen Cables per transfer impedance.

f. and more importantly use a screened motor cable properly terminated at both ends.

It has been common practice to connect communication/signal cable screens at one end to prevent earth loop due to the potential difference at different earth points. But this technique is no longer effective except in special circumstances where:

- a. poor EMC performance achieve from screen cables,
- b. the equipment uses a low frequency signal or
- c. the equipment at the un-terminated end is galvanically isolated.

To avoid current loop drive's manufacturers include into their instruction manuals the appropriate mitigation such as potential equalization conductors in parallel with screen cables.

Actually, if the screen of long cables were connected at one end only, earth faults or lightning surge (with a high electrostatic current dv/dt and a characteristic frequency range of MHz) would be concentrated at the end of un-terminated screen causing potential flashover, fire hazards and electric shock to personnel and damage to the electronic components.

2. Electromagnetic or Inductive Coupling – Magnetic Field dominant

This coupling mechanism is the most frequent cause of problems with noise and interference on signal/communication cables. Hence drive manufacturers include strict electrical installation techniques in their documentation.

As mentioned before, any conductor carrying a current will produce a magnetic field around it and if there is a signal cable adjacent to it a portion of this magnetic field will link to that signal cable.

Faraday's law states that, if the magnetic field produced by source of disturbance (conductor A) changes due to the current changing in conductor A changing, then a voltage will be induced along the length of victim (conductor B) which is directly proportional to the rate of change of the flux linking conductor B. If conductor A is an unscreened motor cable and conductor B is a unscreened communications cable, then this induced voltage represents a noise voltage.

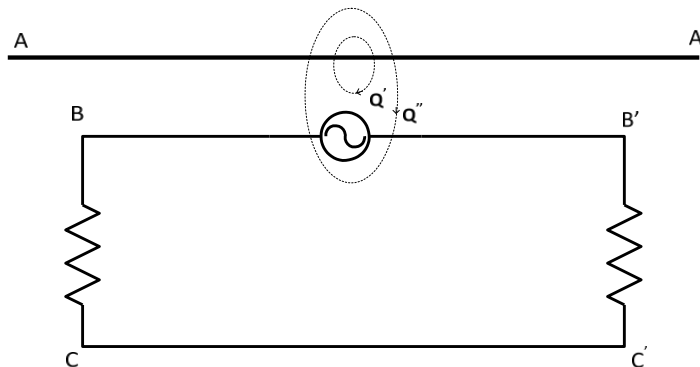

Figure 14 – Voltage induce into the signal/communication cable

The magnitude of the electromagnetic coupled voltage depends on:

- a. The rate of the current change, $V=L \times (di/dt)$
- b. Separation distance of the conductor from the source of disturbance
- c. Size of the signal circuit loop area, see figure 15

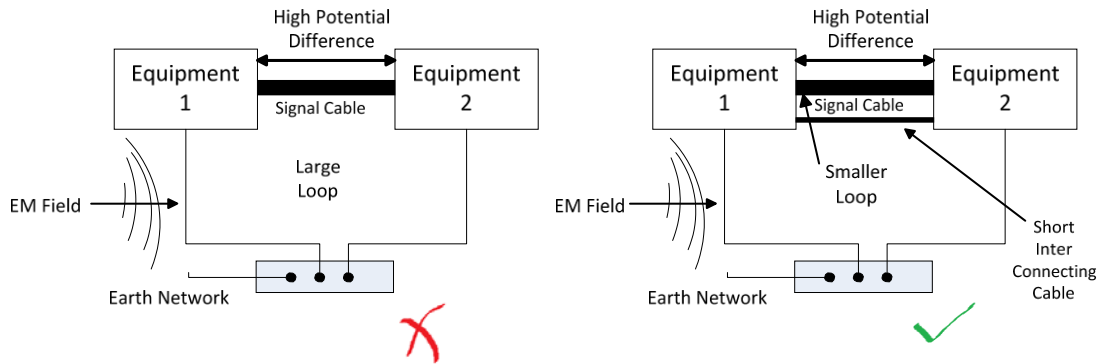

Figure 15 – Size of the loop area

To reduce the effects of the inductive coupling between the source of disturbance (motor cable) and the victim (communication/signal) it is necessary to:

- Increase separation distance between source and victim cables. The flux linkage decreases with increase in the distance between the conductors and hence the induced voltages are reduce.
- Run communication/signal cables along different routes to power cables. Where they need to cross, do it at right angles to each other.
- Twisting of the signal conductor reduces the effective circuit loop area. The tighter the twist the smaller the loop area and lower induced voltage.
- Installing a screen cable to communication/signal and ensure that the screen is properly terminated at both ends.
- and more important use screened motor cable properly terminated at both ends.

3. Electromagnetic coupling

Electromagnetic field coupling is a combination of both magnetic and electric fields affecting the victim circuit simultaneous. This occurs in the free space at distance longer than $\lambda/2\pi$ (known as far field, roughly one sixth of the wavelength) from the source of disturbances, which carries radiating currents and voltages as if they were acting as an antenna. In the far field, both electric and magnetic field components are at the right angle to each other and perpendicular to the direction of the propagation. Examples of transition distances are;

- 1.6 meters at 30Mhz
- 48 meters at 1Mhz
- 16 cm at 300Mhz
- 48km at 1Khz

$$dist > \frac{\lambda[m]}{2 \times \Pi} = \frac{c}{6 \times f} = \frac{300000[km/s]}{6 \times f[kHz]}$$

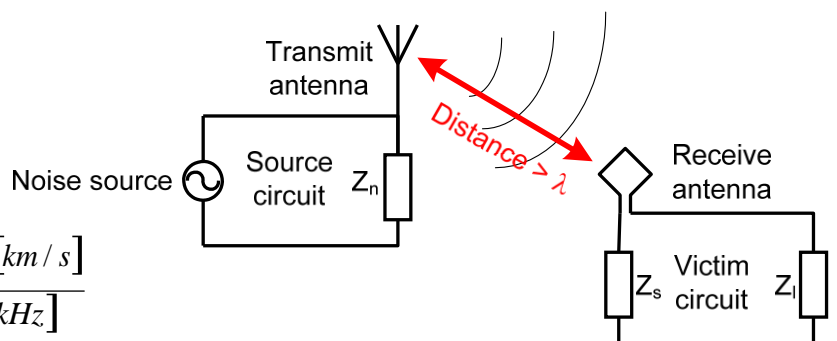

Figure 16 – Electromagnetic coupling

The RF energy is propagating down the transmission line with impedance equal to $Z_0 = 377\Omega$, so:

- a. if the victim impedance is equal to Z_0 the RF energy will be absorbed by the victim and
- b. if the victim impedance is higher than Z_0 a portion of the RF energy will be reflected back.

The motor cable acts like an antenna, so the Radio Frequency energy will radiate to air from the motor cable and could potentially cause interference with other components or cables installed close by. This radiated RF energy (high frequency noise) is typically in the frequency range of 30MHz to 1GHz.

To reduce the effects of the Electromagnetic coupling between the source of disturbance (motor cable) and the victim (other equipment or cables) it is necessary to:

- a. Avoid pigtailed cable screen, this represents a dipole antenna. Using a clamp instead of twisting the screen into a short "pig tail" can be important since at 1MHz the impedance of a 5cm "pig tail" is approximately the same as 150m of the screen.
- b. Avoid making loops (coils) with straps and earth cables
- c. Ensure the motor cable is separated from all other cables (mains input and control cables). Generally at least a minimum separation of 200mm is recommended
- d. Use screened motor cables from the drive to the motor. It must be properly glanded and terminated at both ends and screen continuity is maintained from drive chassis to motor. It is essential that the screen makes contact through 360° to the gland and also that the gland is circumferentially grounded to the gland plate and to the main earth terminations.
- e. Do not break the screen at any point between the VSD and the motor. If there is a local isolator between the VSD and motor for safety purposes, connect the screen continuously with the help of a metal back plate. Connect the screen to the back plate of EMC junction box using proper metal cable clamps.

4. Conductive/Galvanic Coupling

The most frequent example of this is the common earth or power supply connection. Figure 17 shows a typical VSD installation, with the VSD connected to the mains supply transformer (with a total impedance of the transformer + cables represented by Z) and the VSD connected to the motor using a standard unscreened 3 core plus earth cable. The VSD and motor are both earthed to the power earth (PE) of the installation for safety reasons as is normal practice. RF energy created by the VSD is represented as I_1 which travels along the motor cable to the motor. I_1 will take the lowest impedance closed circuit to return to its source (the VSD). Stray capacitances (C_s) are formed between the 3 motor cable cores and earth core, between the motor windings and motor frame and between the motor frame and the earth plane. All these stray capacitances are relatively low impedance paths for the high

frequency noise (I1) and therefore in an installation using unscreened motor cable as shown in Figure 17, it can return to its source via many different potential paths (I2, I4 and I5).

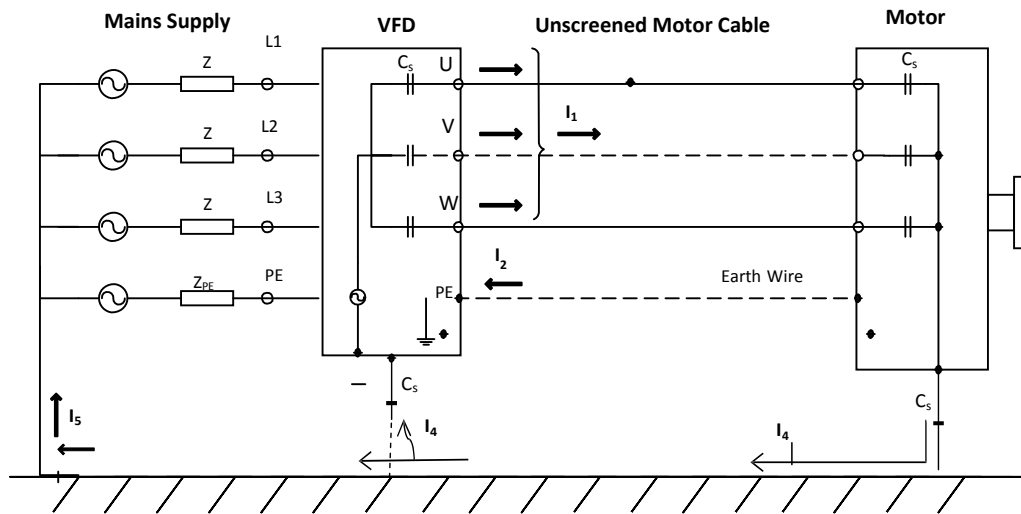

Figure 17 – VSD EMC installation with RF energy created (I1)

It is important to ensure that the level of noise conducted back to the VSD via the mains supply (I5) is kept to a minimum because all other equipment in the installation is also connected to this same mains supply and could therefore be affected by this noise.

Note, longer motor cables have more capacitance and therefore the noise leakage current I1 (and therefore also the proportion I5) will be higher with longer cables.

To reduce the level of conducted mains supply high frequency current I5 it is necessary to

- Install a VSD with an RFI filter. The RFI filter provides a low impedance path to high frequencies from the earth plane of the VSD to the “noise generator” within, figure 18.
- Use screened motor cable. The screen provides a high frequency low impedance path for the leakage currents. At high frequencies the impedance of a typical braided screen is much lower than that of the standard earth core in the motor cable.
- Earth the screen at both the VSD and motor using a high frequency, low impedance connection.
- Low impedance earth system

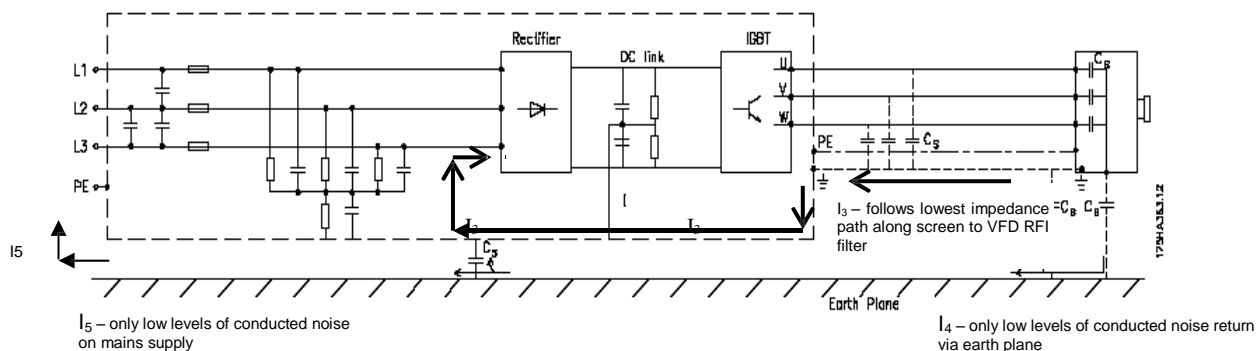

Figure 18: Correct VFD EMC installation with integrated RFI filter and screened motor cable earthed at both VFD and motor

Kirchoff's Law states that the sum of the currents at any electrical node is always zero, so for every send current (signal or power) there is always an exactly equal and opposite return current, even where it returns through a number of different paths. The total path of a current is often called a current loop and it is incorrect to make the assumption that return paths (earth) have zero impedance.

Note that the inductive impedance of a straight length of wire exceeds its resistive impedance above a few kHz. As frequencies increase the impedance (Z) of the cable increases (as per $Z = 2 \times \pi \times f \times L$); and at even higher frequencies, when the wavelength has become comparable with the length of the wire it will behave as resonant antenna and its impedance will appear either inductive or capacitive depending on frequency.

The impedances at high frequencies depend upon their material, shape (especially cross-sectional area), length, and proximity to other conductors. Typically rectangular areas of conductor maintain lower impedances than round wires at higher frequencies, so does the reason why a wide braid strap is better than a wire at high frequencies for earthing.

Note that knowing where the return current flows is a powerful tool to achieve EMC, hence an analysis on the differential mode and common mode currents.

Common Mode Currents vs. Differential Mode currents

In all circuits both common mode (CM) and differential mode (DM) are present, and they define the amount of RF energy propagating down the transmission line or radiated into the free space. The main difference between both currents is that DM carry data or signal of interest while CM cause problem for EMC.

DM is the component of the RF energy which is present in both the signal and return path which is equal and opposite to each other.

For example if 1A of RF propagated from the source to the load represented here by I1 on figure 19, the same 1A of RF must return to the source through the return path represented by I2, (in this case $I1=I2$). This represent a perfectly balance transmission line system which does not propagate any EMI.

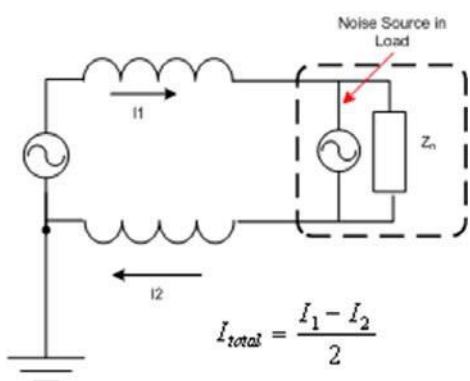

Figure 19 – Differential Currents

On the other hand, CM is the component of RF energy which is present in both the signal and return path that is often in phase to each other. Therefore, the RF energy due to CM currents will be the sum of the currents that exist in both signal and return path.

For example, 0.5A of RF propagate from each of the output terminals of the source represented by I1 and I2 on figure 20. I1 and I2 currents are equal in polarity so the sum of both (I1+I2) will be different from zero. This violates the Kirchoff's law unless the 1A of RF return to the source through alternative return paths such as free space, common earth plane, etc.

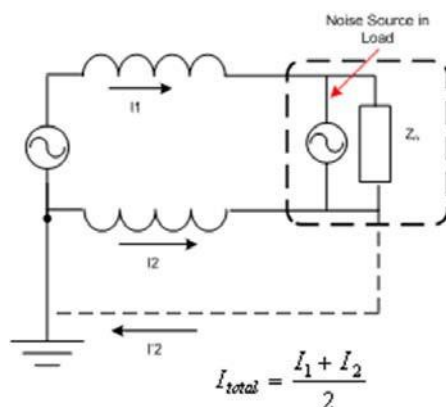

Figure 20 – Common Mode Currents

In order to limit the common mode current propagated on the output motor cables represented as I1 on figure 17, it is imperative to ensure lowest impedance path for the CM current to return to its source by:

- a. Using screened motor cable.
- b. Earth the screen at both the VSD and motor using a high frequency, low impedance connection.
- c. It is also important to ensure this high frequency low impedance path between the motor and VSD is maintained even if the local motor isolators are installed between the VSD and motor.
- d. Low impedance on the earth system

Earth, ground, protective conductors, common bonding networks and earth mass

Earth and ground could mean different things to many electrical engineers. Both words can be used to mean either protective conductor (PE), the common bonding network of buildings/plants, earth mass electrodes of the lightning protection system or the conductor of the mains supply that is connected to an earth electrode at the transformer side (Neutral).

Strictly speaking, earthing should only refer to a connection to the mass of the Earth, particularly the earth electrodes of a lightning protection system or the earth electrode that connects to one of the mains terminals of an AC mains distribution transformer (usually the Neutral under MEN system in Australia and New Zealand).

Earth and ground are synonymous; where earth is used in Europe, Australia and New Zealand and ground is used in the US and Canada.

The primary goal of an earthing system is to assure personnel safety and protection of installations against damage such as lightning and power system faults. These can cause circulation of large currents, which might create hazardous voltages in installation structures.

The task of the earthing system is to be a path to the soil for currents, while maintaining voltage differences between any two points of an installation as low as possible under both operational and fault conditions. The PE conductor is typically the green/yellow wire that is included with the mains cords and is connected to the building common bonding network. The prospective touch voltage within the installation is then the product of the impedance of the protective conductor and earth fault current. These PE conductors alone are generally not sufficient to fulfill the EMC requirements. Thus, the PE conductor cross section typically is no less than 10mm² for three phases equipment with leakage current greater than 3.5mA.

The secondary goal of an earthing system is to serve as a common voltage reference and to contribute to the mitigation of disturbances as it is the path for the return of high frequency current between the source of disturbances and sensitive equipment.

This paper does not cover the safety aspects as such and it only concentrates on the secondary goal. But by no means must safety be compromised for the benefit of EMC.

Typically in the design of the earthing system the following points are considered:

- a. Lightning and personnel safety which dictates the design of the earth electrode;
- b. safety and installation protection which dictates the size for the earthing conductors; and
- c. the EMC which dictates the surface area size of the earthing conductor (not the cross section since HF currents flows on the surface due to skin effect) and it also determines the layout of the earthing network. Bear in mind that EMC earthing usually take

advantages of distributed structural components that are part of the whole system such as chassis, enclosure panel, etc.

Let's briefly discuss the pro and cons of Independent earth-, Star Earth- and Common Bonded Network systems in relationship to a good EMC earthing.

The use of independent earthing is not suitable for EMC and is well understood to create safety hazards especially when large currents flow, i.e. due to lightning strike, the independent soil electrodes can take on very different voltages causing electrical shocks, arcs, fire, and equipment damage.

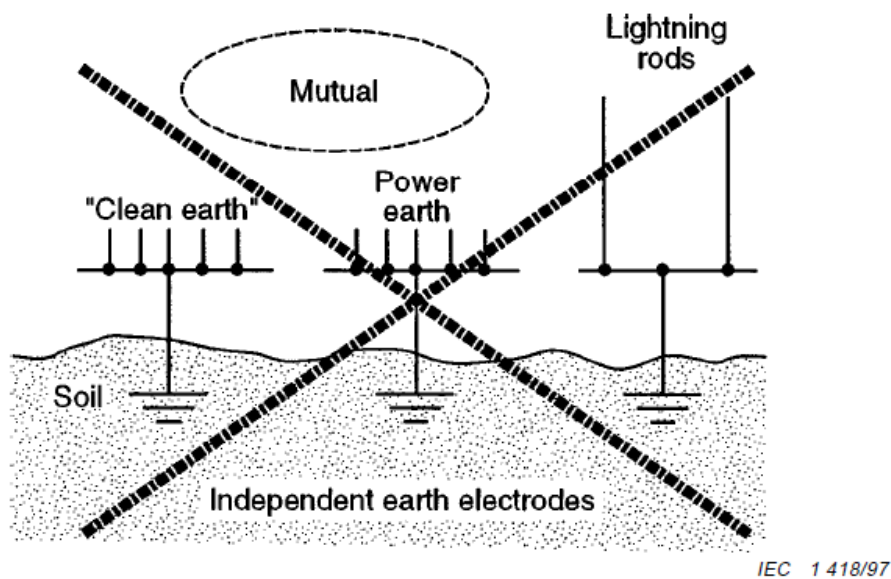

Figure 21 - Independent earthing system

Star (or single earth electrode) Earthing topology is able to provide safety but only at 50Hz and requires to be well maintained. However, it is not effective to control earth loops at higher frequency due to inductance and/ capacitive coupling.

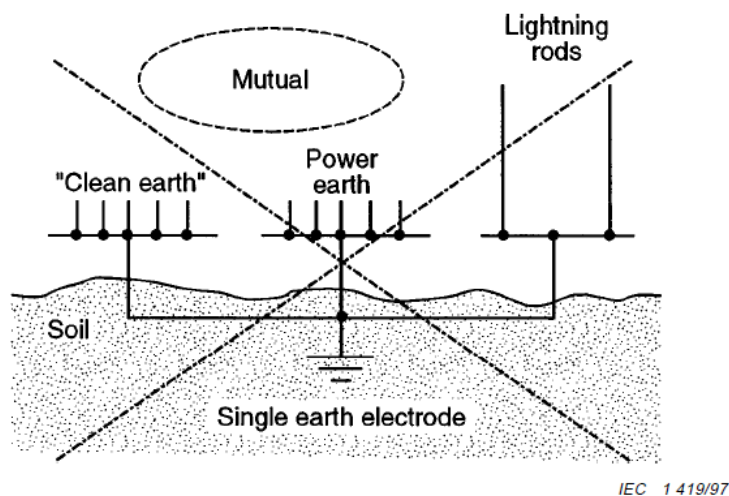

Figure 22 - Star earthing system

Common Bonded Network (CBM), often refer to Mesh Bonding Network (MESH-BN) achieves safety, signal integrity, equipment reliability and also EMC. To reduce potential earth loops and keep them under control bonding of every piece structural and non-structural metal work together is required.

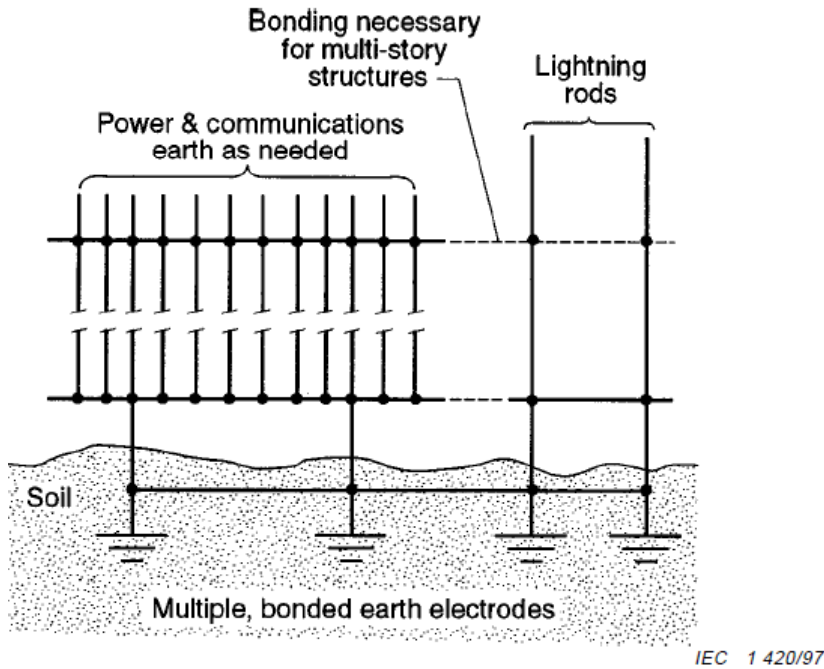

Figure 23 - Common Bonded Network (CBM)

The MESH achieves low impedance for 50Hz up to higher frequencies depending on its average size. The dimension of the MESH is still not quite clearly defined but, as a rule of thumb smaller MESH is required to prevent voltage drop due to earth inductance and where sensitive equipment is used. The MESH is well adopted in IT and Telecommunication buildings, however is not always practical and economical to implement in a large industrial areas.

It is recommend using natural metalwork such as re-hars, girders, structural metalwork and any other metalwork to help to achieve the MESH-BN. The bonding should ideally be metal-to-metal, and seam welding is best. Short conductors may be used instead with a reduction in high- frequency performance. Figures 24 to 29 show examples of effective bonding.

Figure 2F Bonding conductors
Only use bonding conductors where direct metal-to-metal bonding is not practical

- Long wire is OK for DC-60Hz but poor for higher frequency EMC
- Minimum wire length is better for control of higher frequencies
- Short, wide braid strap on its own is good up to approximately 3MHz
- Short wide metal plates (with multiple bonds) are better for controlling high frequencies, but direct metal-metal bonds are the best

Figure 2G Bonding cable trays and ducts

- Long wires OK for DC-60Hz, but poor for higher frequencies
Short, wide braid straps would be better than wires (preferably one on each side)
- U-brackets with multiple fixings are better for controlling high frequencies
But seam-welded joints are the best
- Covers and lids only assist EMC if they make electrical contact along whole length

Figure 24 – Bonding conductor

Figure 25 – Bonding cable trays

For bonding straps, suitable conductors include metal strips, metal mesh straps or round cables. For these high frequency systems, metal strips or braided straps are better (skin effect). A typical dimensional length/width ratio for these straps should be less than five.

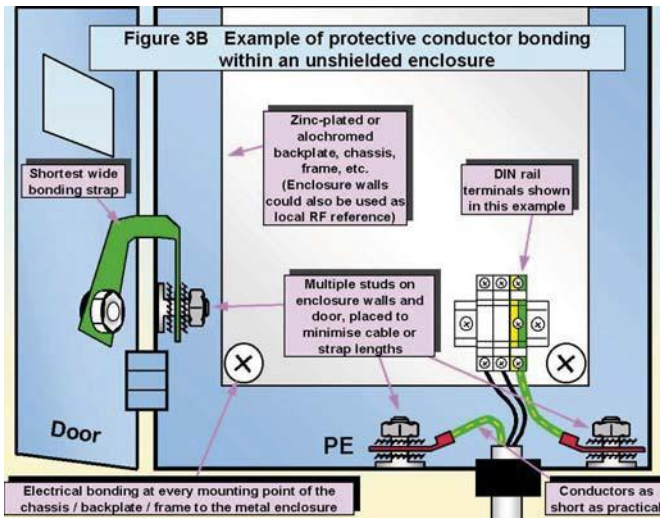
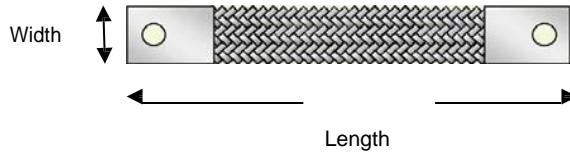

Figure 26 – Bonding in an enclosure

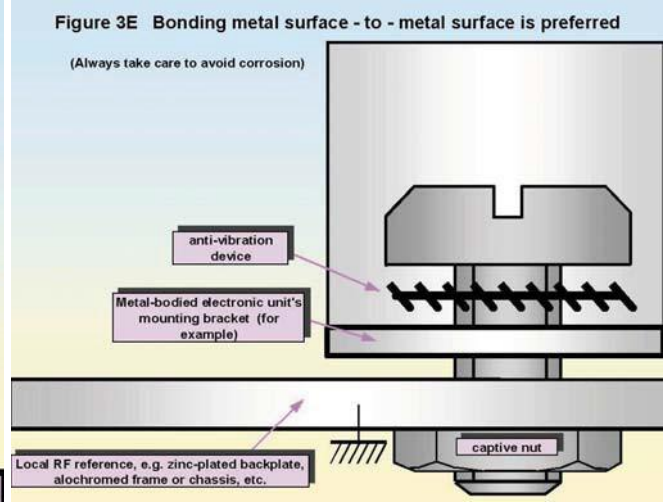

Figure 27 – Bonding metal to metal

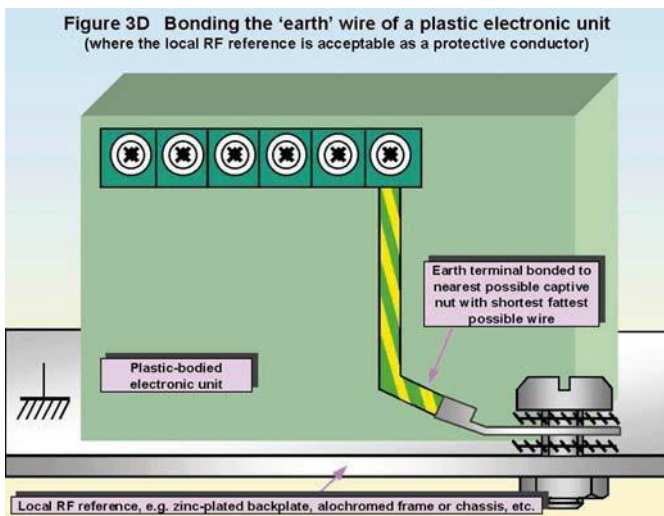

Figure 28 – Bonding Earth

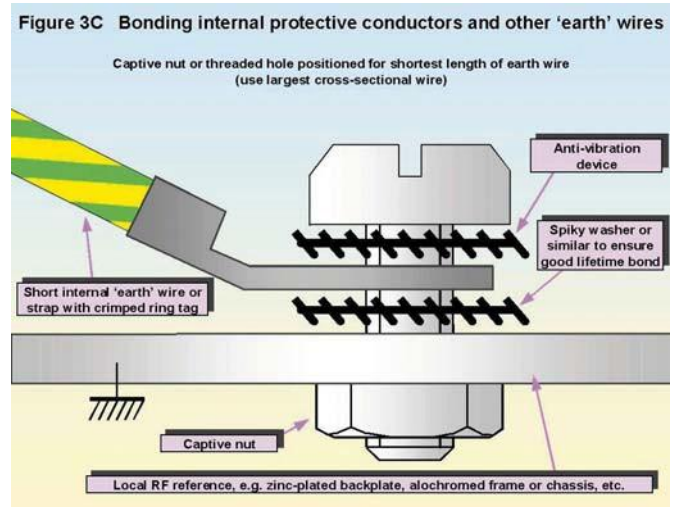

Figure 29 – Bonding PE conductor

Making the EMC plan for PDS to meet EMC requirements

Making the required planning for the electrical installation of the PDS is critical in order to achieve EMC performance, this will increase project time scales while avoiding loss of revenue due to additional site visits to resolve EMI issues.

Step 1 - Determine the environment type and the allowable EMC levels as per standard AS 61800.3.2005 and/or EMC Code of practice

Step 2 - Select the suitable drive for the application with the required input RFI filter to meet the required EMC level. Bear in mind that all VSDs have a maximum motor cable length for which their RFI filter has been designed. This is an important factor to consider when assessing the suitability of a VSD for an installation. It may be necessary to fit additional RFI filters with some VSDs depending on the motor cable length to reduce the conducted mains supply noise levels low enough to reduce the probability of EMC problems in the installation. When the motor cable length is longer than the limit specified by the VSD manufacturer it is no longer possible to guarantee the EMC performance of the filter (in other words not able to meet the required limits). Furthermore, if the cable length goes beyond the design of the RFI functionality problem will arise such as, RFI coil saturation due to higher CM currents, over heat of the RFI coil and increase of losses on the IGBTs due to higher capacitance current.

Step 3 - Select the additional components which comprise the power drive system (PDS) to ensure meeting with the required EMC level such as;

- a. EMC motor/VSD glands. Some drive manufacturers include EMC glands to secure the screen at the drive end with their products while others don't.
- b. Motor screen cable to meet the appropriate performance. Two factors are important for the selection, the screen coverage of at least 80% and low transfer impedance. A single layer braided copper screen has proven to be extremely effective.
- c. EMC/metal junction boxes with their EMC saddles to secure the screen properly through 360 degree contact, with NOT pigtail
- d. Signal/Communication screen cables with appropriate properties as per product manufacturer. Typically copper-braided screen or braided screen achieves best results.
- e. Separate cable trays for power and signal cables with their bonding

Step 4 - consider the best routing of the power and signal cables between all equipment comprising the PDS to avoid RF energy coupling into sensitive cables, so it is important to:

- a. When crossing is unavoidable, the signal cable must cross motor cables at an angle of 90 degrees.
- b. Identify the power cables which may carry RF energy (noise) and the sensitive cables (signal/communication) to ensure correct cable segregation. Drive manufacturers often state in their documentation recommended segregation distances between power and signal cables as shown on figure 30.

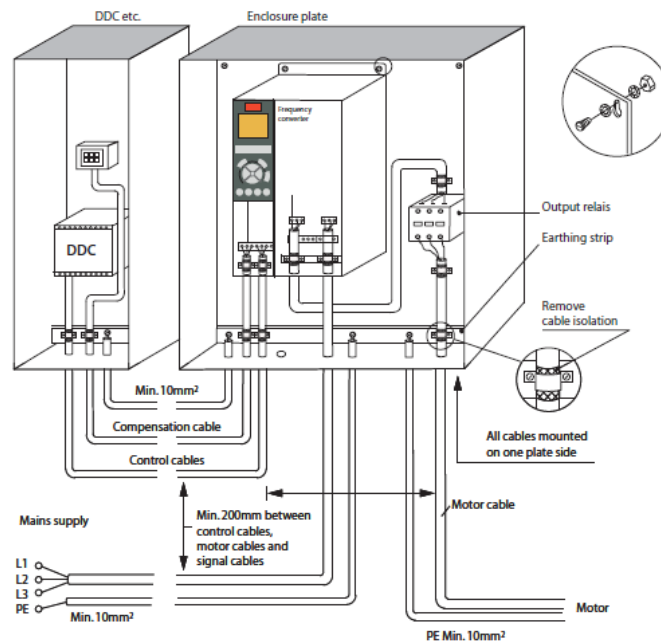

Figure 30 - EMC-correct Electrical Installation of a Danfoss VSD in enclosure

However, if this information is not available the following segregation as per cable classification can be considered.

Class 1: Applies to cables carrying very sensitive signals such as thermocouples, thermistors, RTD, strain gauges, load cells, flowmeters with millivolt-level signals, and high-speed digital communication (Ethernet).

Class 2: This covers ordinary analogue signals such as analogue signals (4-20 mA, 0-10V, or signals below 1 MHz), low-speed digital signals (RS232, RS485), digital (on/off) signals.

Class 3: Applies for cables carrying slightly interfering signals: AC power supply (<1kV), DC power (24 V), power to equipment with RFI/EMI filters, control circuits with resistive or suppressed inductive loads, direct-on-line (DOL) induction motors.

Class 4: Applies to the cables associated with the power inputs and outputs of VSD. These cables carrying strongly interfering signals: motor cables, DC-link load sharing, unsuppressed inductive loads, DC motors, etc.

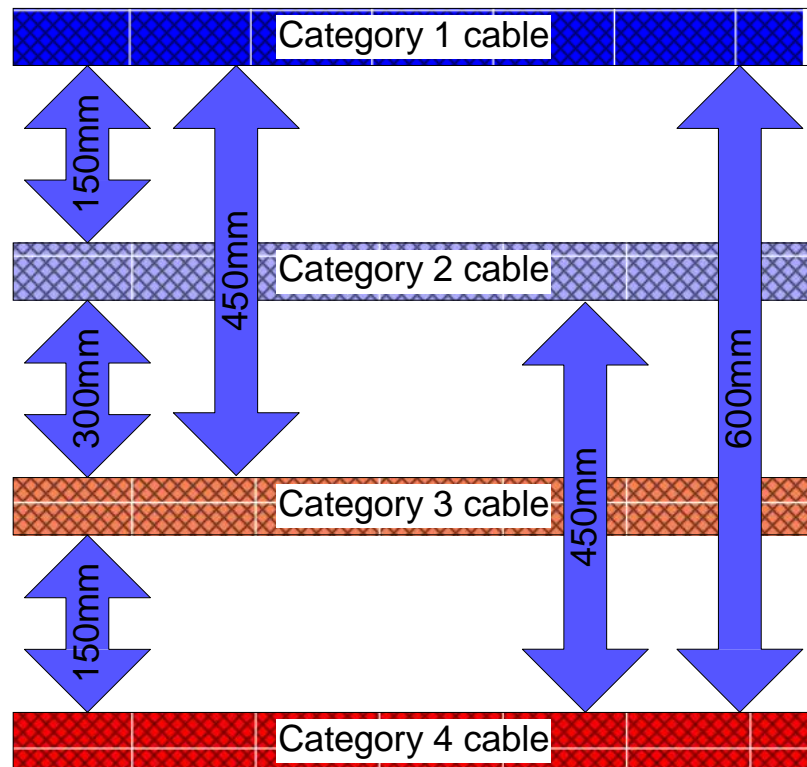

Figure 31 – Cable segregation as per

Step 5 – Electrical Installation

- a. It is essential that screened cables are “properly” glanded and terminated. This means to ensure that the screen makes contact through 360 to the gland and also that the gland is circumferentially grounded to the gland plate and to the main earth terminations at both ends.
- b. Protective Conductor Earth (PE) must be inside the cable screen and terminated by very short connection at the same place as screen at both ends
- c. Do not break the screen at any point between the VSD and the motor. If there is a local isolator between the VSD and motor for safety purposes, connect the screen continuously with the help of a metal back plate. Connect the screen to the back plate using proper metal cable clamps.
- d. Avoid pigtails at cable screen.
- e. Avoid making loops (coils) with straps and earth cables
- f. Avoid crossing or bonding of motor cables with mains supply cables, control cables or fieldbus cables.
- g. Use star-washers to secure low impedance from chassis to back-plate whenever is possible

Step 6 – Always follow manufacturer recommendation regarding the mechanical & electrical installation to ensure good EMC installation.

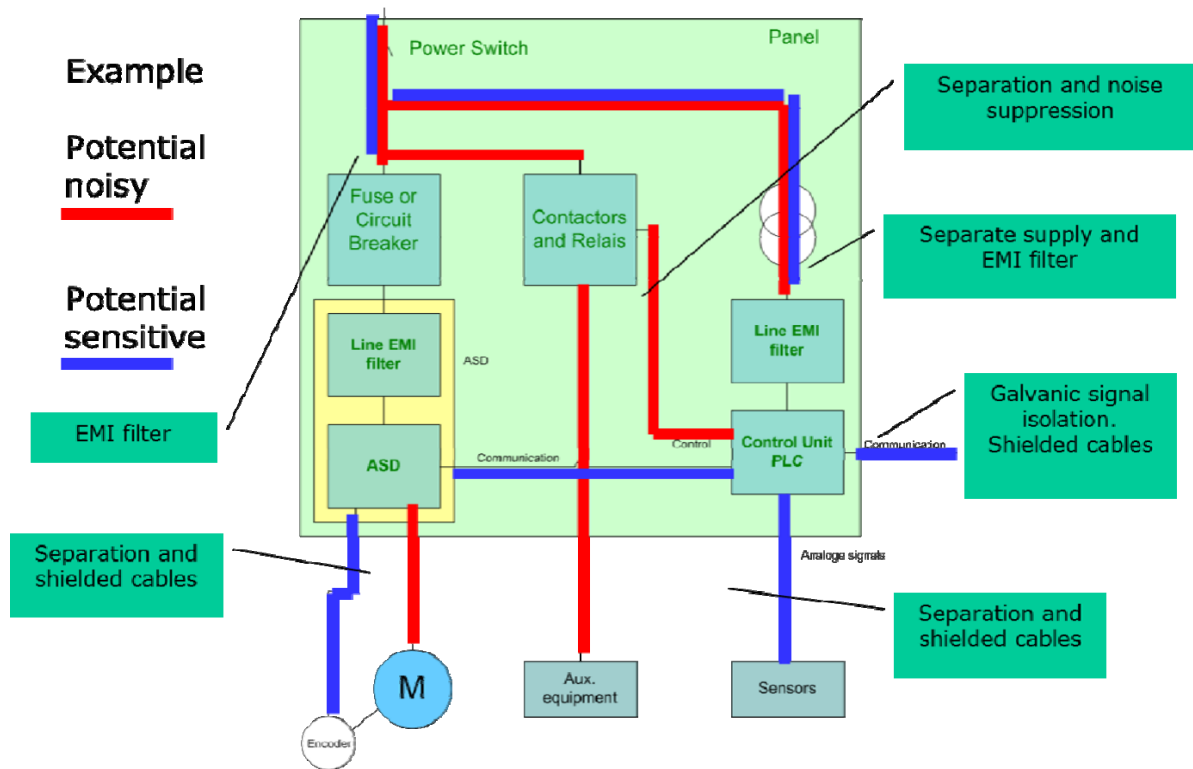

Figure 32 – Example of an EMC Plan

Conclusion

The Installation of Power Drive System plays a very important role in the EMC performance, and it should never be underestimated. Not following the best EMC installation practice typically state in every VSD' manufacturer documentation can lead to a very time consuming and costly exercise to resolve EMI issues. Note that RFI filter with VSD do not eliminate the EMI by itself and/or the use of a screen motor cable incorrectly terminate (i.e. via pigtail) does not automatically eliminate the potential EMI. Nowadays with vast sensitive electronic equipment and fast communication fieldbuses available it is imperative to make a good EMC plan to avoid any potential coupling mechanism while complying with EMC limits. These days environments are highly polluted with frequencies higher than 50Hz and up to Mhz, so it is required to characterize the earth system by its impedance and not only by its resistance like in the old days. An analysis of the earth's system and its effectiveness to achieve EMC performance became a typical onsite practice. This can be done by measuring the differential mode (DM) and common mode (CM) currents on the return paths.

References

- [1] GAMBICA/REMA User guide no. 2 Motor Shaft Voltages and Bearing currents
- [2] GAMBICA/REMA User guide no. 3 Installation Guidelines for Power Drive Systems
- [3] AS61800.3.2005 Adjustable Speed Electrical Power Drive System
IEC/TR 61000.5.2 Electromagnetic Compatibility - Installation and mitigation guidelines, earthing and cabling
- [4] IEC 60034-17: 1998, Rotating electrical machines: cage induction motors when fed from converters - Application guide
- [4] NEMA 'Application Guide for AC Adjustable Speed Drive Systems'
- [5] Testing for EMC Compliance. Mark Montrose – Edward Nakauchi
- [6] Danfoss Design Guide MG.33.BC.02
- [7] Danfoss Output Filters Design Guide MG.90.N2.02
- [8] Danfoss Operating Instruction Manual MG.11.AE.02
- [10] Determination of effective screen design for VSD cables. Technical Department General Cable New Zealand
- [11] Stray voltage Detection – Midwest Rural Energy Council
- [12] Stray Voltages IEEE Industry Application Magazine
- [13] EMC Compliance Code of Practice for the Supply, Installation and operation of PDS (August 2011)
- [14] EMC for System and Installation Tim Williams & Keith Armstrong
- [15] Installation Cabling and Earthing Techniques for EMC, Keith Armstrong
- [16] Earth? What earth? Keith Armstrong
- [17] Harmonics and RFI design aspect of VFD integrated HVAC solution, Andrew Cooper
- [18] EMC for installation – practical design and assessment methods Richard Hoad and Adrian Leaver